

PULL BOX FOR SECONDARY SYSTEM

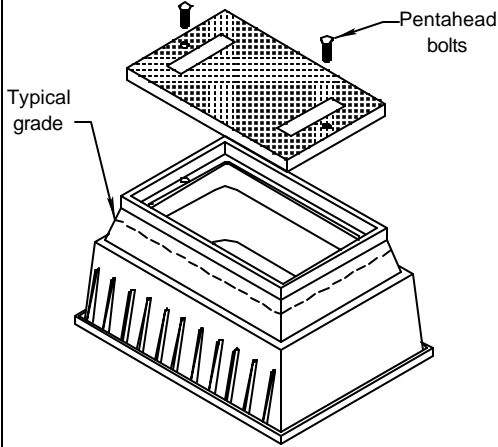

Plastic or fiberglass for grass areas or Polymer concrete for light duty areas (see notes 2, 3, & 4)

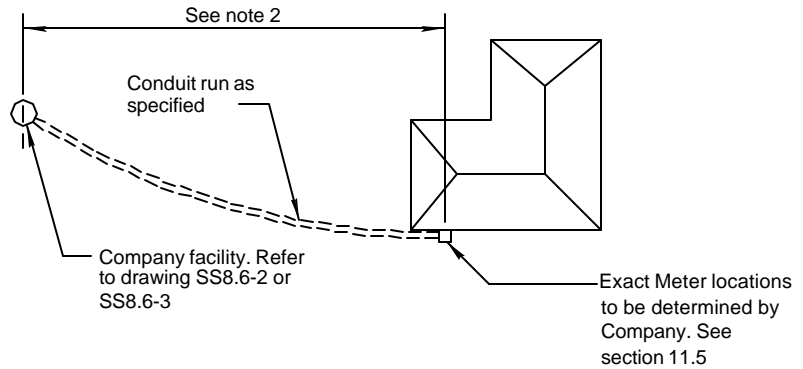

STANDARD SERVICE INSTALLATION

911 address shall be a minimum 3" lettering marked on structure, or meter enclosure and should be visible from street.

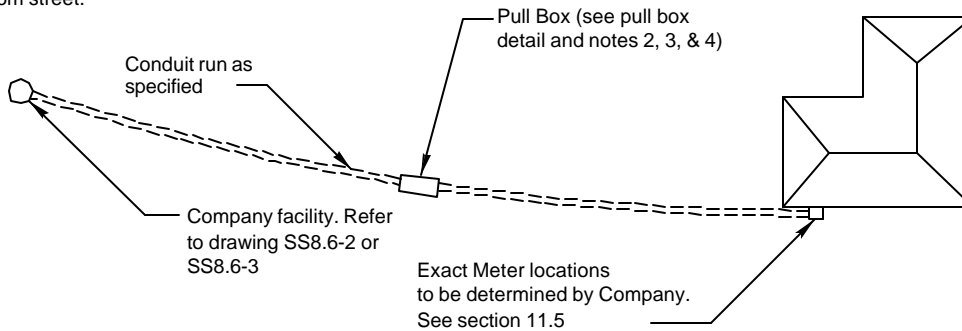

STANDARD SERVICE INSTALLATION WITH PULL BOX

Notes:

1. Customer facilities shall comply with Company Standards, the NEC, and authorities having jurisdiction.
2. Customer shall consult with company for location and type of pull box for any length over 200'.
3. If more than three 90° bends (including riser bends and regardless of length) are required in any run, consult the company.
4. Pull box shall be installed at a 90° bend or the center of run and be of sufficient strength to support probable local traffic (consult Company for box in areas with traffic or trucks driving over boxes). Recommended size: 17" W X 30" L X 18" D.
5. The Customer shall bear the cost of conduit and its installation.
6. See table for conduit diameter.
7. The customer shall install 80lb non-metallic (manila or grass) pull line or bull tape in the conduit. Conductor normally supplied by Company.
8. Underground service conduit shall be separated from telephone, cable, or water facilities by not less than 3" of concrete, 4" of brick masonry, or 12" of well tamped earth and 18" of well tamped earth for gas facilities (NESC 320.B.2 and NESC 354.A.2).
9. Conduit shall bear the U.L. label, either rigid nonmetallic (schedule 80 PVC above ground, schedule 40 below grade, gray only) or rigid /intermediate metal conduit (aluminum not permitted below grade). If metal conduit is used below grade, corrosion protection shall be provided.
10. Conduit required in restricted areas.
11. Additional details are found in other drawings SS8.6-2, SS8.6-3, SS8.6-4 and SS8.6-5.

CONDUIT SIZE REQUIRED	
TRIPLEX CONDUCTOR SIZE (AWG)	CONDUIT DIAMETER
1/0 4/0	2.5"
1/0 4/0*	2" Arkansas only
350 kcm	3"

* ARKANSAS ONLY

**Call 48 Hours Before You Dig
1-888-258-0808**

In locations with underground facilities, the Customer shall notify One Call and shall have One Call locate all underground facilities before digging. It shall be the responsibility of the Customer to stay clear of all underground facilities.

ENTERGY SERVICES, INC.	
TYPICAL CONDUIT SYSTEM REQUIREMENTS FOR SINGLE PHASE CUSTOMER UNDERGROUND SERVICE	
APPROVED BY: JDS	DATE: April 1998
CHECKED BY: LKE	SCALE: NONE
DRAWN BY: WINK-AJC	
No. SS8.6-1	
PLOT 1=1 SH. 1 OF 1	

4	2/05	UPDATED: CUSTOMER INSTALLATION STANDARDS TEAM	DAT	
3	4/02	UPDATED: CUSTOMER INSTALLATION STANDARDS TEAM	DAT	
2	5/99	UPDATED PER SERVICE STANDARDS TEAM	TKV	
1	6/98	UPDATED PER SOLUTIONS GROUP RECOMMENDATIONS	MCC	
NO.	DATE:	REVISION	BY:	APPR:

CONDUIT PLACEMENT

Meter socket shall be designed for underground service installed and maintained by customer (Meter enclosure minimum required size is 4 1/8" D x 11" W x 15 1/2" H). Main breaker should be within 2'-0" of the meter. Outside wall recommended.

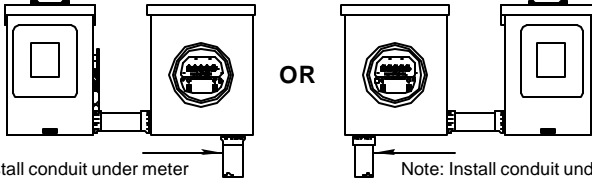

Note: Install conduit under meter socket on opposite side of switch

Note: Install conduit under meter socket on opposite side of switch

911 address shall be a minimum 3" lettering marked on structure, or meter enclosure and should be visible from street.

Call 48 Hours Before You Dig

1-888-258-0808

In locations with underground facilities, the Customer shall notify One Call and shall have One Call locate all underground facilities before digging. It shall be the responsibility of the Customer to stay clear of all underground facilities.

Pad mount transformer or secondary pedestal (furnished and installed by Company)

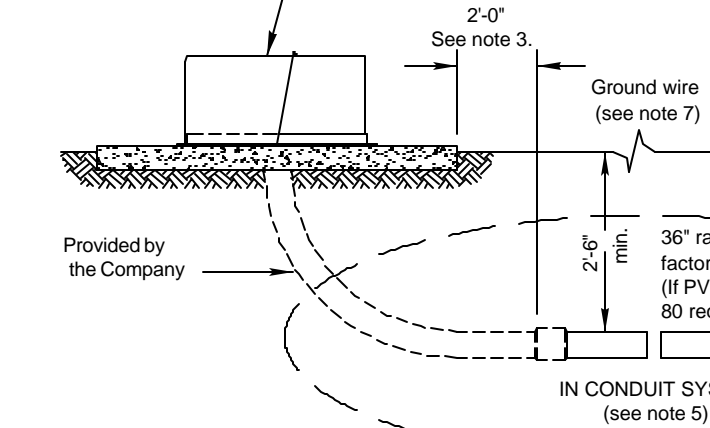

Conduit, elbow attachments, and bushings to be furnished and installed by Customer
See drawing SS8.6-4

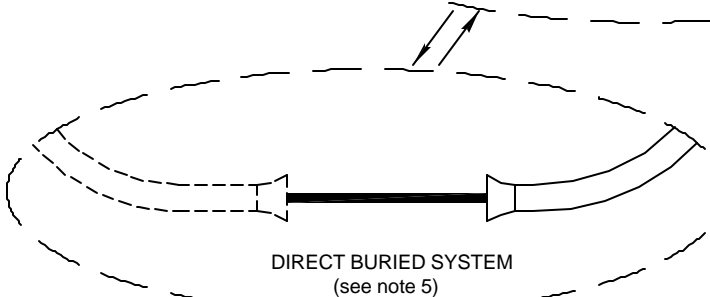
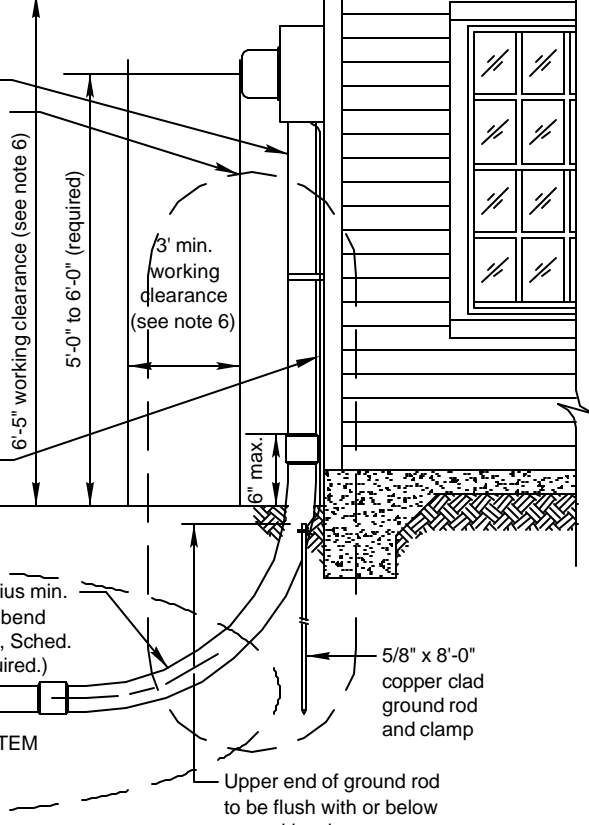

NOTES:

1. Customer facilities shall comply with Company Standards, the National Electrical Code, and authorities having jurisdiction.
2. Meter enclosure shall be installed and maintained by the customer.
3. Conduit system shall be installed to within 2'-0" of the transformer pad or secondary pedestal. End of conduit to be sealed and location marked. Consult Company for specific location.
4. The customer shall install 80lb non-metallic (manila or grass) pull line or bull tape in the conduit. Conductor normally supplied by Company.
5. Consult a Company Representative for required system in your area.
6. See drawing SS8.6-6 for equipment work clearance.
7. For grounding information see section 13.5.

Minimum Customer Wiring Size - Family Residence Single Phase

METER SIZE	CONDUIT SIZE	Current carrying & neutral wire size (per NEC)		GROUND WIRE SIZE
		ALUMINUM	COPPER	
100 Amp	2"	#2	#4	#6 *
200 Amp	2.5" ***	4/0	2/0	#4 **
320 Amp	3"	Consult NEC		

See NEC 310.15(B) (6) - phase conductors: NEC 220.61 - Neutral, and NEC 250.66 - Ground Wire
* Wire smaller than #6 must be protected from physical damage (see NEC 250.120C)
** For sole connection to rod, plate or pipe type electrode #6 AWG Cu is allowed (see NEC250.66A)
*** Arkansas locations only allows 2"

NO.	DATE:	REVISION	BY:	APPR:
5	3/08	UPDATED: CUSTOMER INSTALLATION STANDARDS TEAM	DAT	
4	2/05	UPDATED: CUSTOMER INSTALLATION STANDARDS TEAM	DAT	
3	4/02	UPDATED: CUSTOMER INSTALLATION STANDARDS TEAM	DAT	
2	5/99	UPDATED PER SERVICE STANDARDS TEAM	TKV	
1	6/98	UPDATED PER SOLUTION GROUP RECOMMENDATIONS	MCC	

ENTERGY SERVICES, INC.

PADMOUNT TRANSFORMER OR SECONDARY PEDESTAL SERVING A CUSTOMER

APPROVED BY:	JDS	DATE:	April 1998
CHECKED BY:	LKE	SCALE:	3/8"=1'-0"
DRAWN BY:	WINK-AJC		
		No. SS8.6-2	
PLOT	1=1	SH.	1 OF 1

CONDUIT PLACEMENT

Meter socket shall be designed for underground service installed and maintained by customer (Meter enclosure minimum required size is 4 1/8" D x 11" W x 15 1/2" H).
Main breaker should be within 2'-0" of the meter. Outside wall recommended.

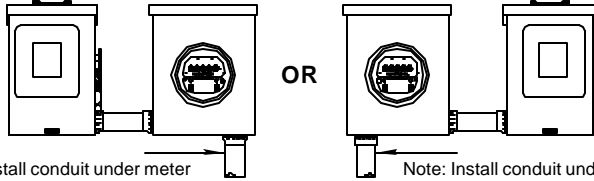

Note: Install conduit under meter socket on opposite side of switch

Note: Install conduit under meter socket on opposite side of switch

Call 48 Hours Before You Dig
1-888-258-0808

In locations with underground facilities, the Customer shall notify One Call and shall have One Call locate all underground facilities before digging. It shall be the responsibility of the Customer to stay clear of all underground facilities.

When installing conduit system, Customer shall extend conduit to pole or underground system. Consult the Company for details. (See drawings SS8.6-2 and SS8.6-3)

Threaded coupling, adapter, or sleeve as appropriate.

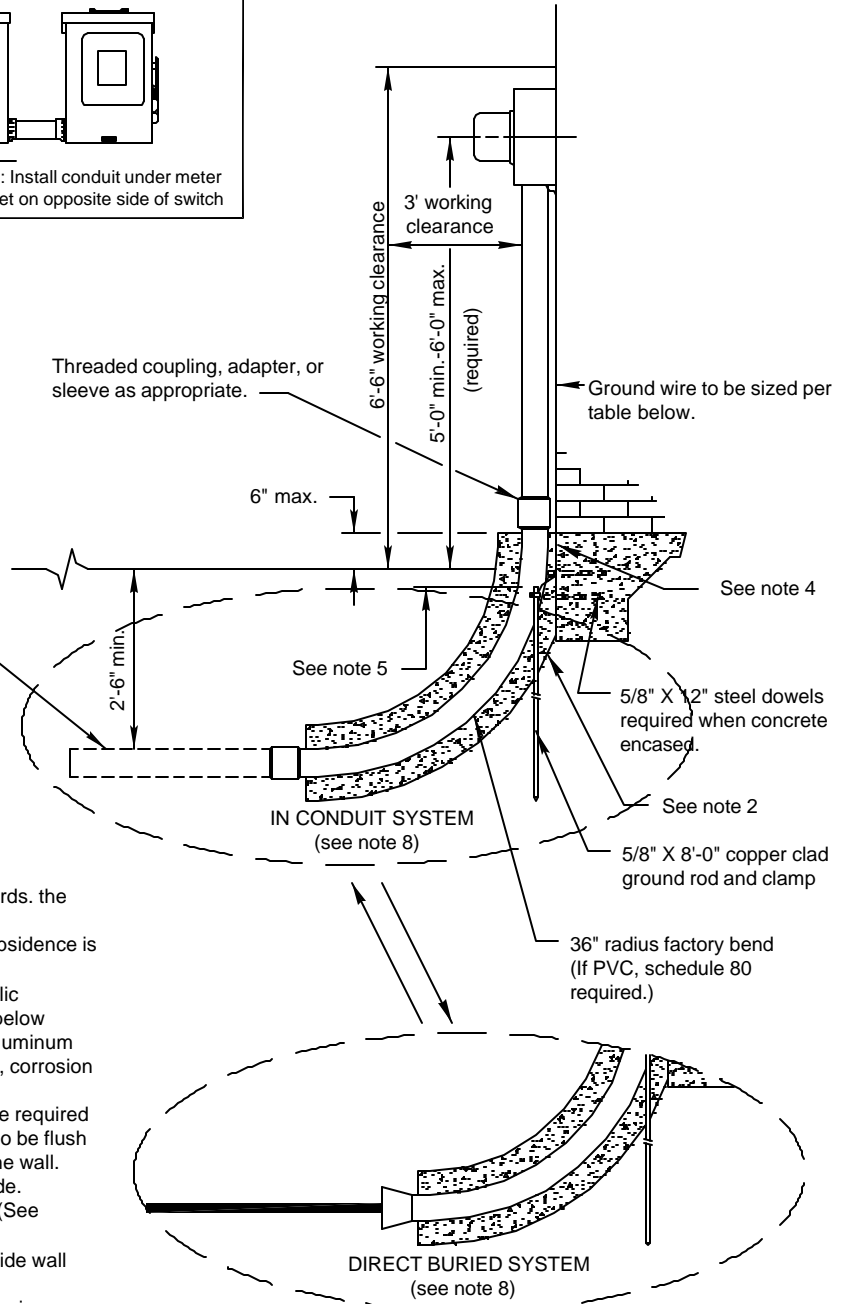

Notes:

- Customer facilities shall comply with Company Standards, the NEC, and authorities having jurisdiction.
- Concrete encasing on elbow is required where soil subsidence is possible, consult with Company.
- Conduit shall bear the U.L. label, either rigid nonmetallic (schedule 80 PVC above ground and schedule 40 PVC below ground, grey only) or rigid/intermediate metal conduit (aluminum not permitted below ground line). If metal conduit is used, corrosion protection shall be provided.
- Conduit shall be flush with wall. The foundation may be required to have blocked out area for conduit in order for conduit to be flush with wall when installed. Conduit is not allowed behind the wall.
- Upper end of ground rod to be flush with or below grade.
- Conduit required in restricted access or paved areas. (See section 8.6.1)
- Main breaker should be within 2'-0" of the meter. Outside wall recommended.
- Consult a Company Representative for required system in your area.

Minimum Customer Wiring Size - Family Residence Single Phase

METER SIZE	CONDUIT SIZE	Current carrying & neutral wire size (per NEC)		GROUND WIRE SIZE
		ALUMINUM	COPPER	
100 Amp	2"	#2	#4	#6 *
200 Amp	2.5" ***	4/0	2/0	#4 **
320 Amp	3"	Consult NEC		

See NEC 310.15(B) (6) - phase conductors: NEC 220.61 - Neutral, and NEC 250.66 - Ground Wire

* Wire smaller than #6 must be protected from physical damage (see NEC 250.120C)

** For sole connection to rod, plate or pipe type electrode #6 AWG Cu is allowed (see NEC250.66A)

*** Arkansas locations only allows 2"

NO.	DATE:	REVISION	BY:	APPR:
4	3/08	UPDATED: CUSTOMER INSTALLATION STANDARDS TEAM	DAT	
4	2/05	UPDATED: CUSTOMER INSTALLATION STANDARDS TEAM	DAT	
3	4/02	UPDATED: CUSTOMER INSTALLATION STANDARDS TEAM	DAT	
2	5/99	UPDATED PER SERVICE STANDARDS TEAM	TKV	
1	6/98	UPDATED PER SOLUTION GROUP RECOMMENDATIONS	MCC	

ENTERGY SERVICES, INC.

DETAILS FOR TYPICAL SINGLE PHASE RESIDENTIAL UNDERGROUND SERVICE AT HOUSE

APPROVED BY: JDS DATE: April 1998

CHECKED BY: LKE SCALE: NONE

DRAWN BY: WINK-AJC



No. SS8.6-4

PLOT 1=1 SH. 1 OF 1

UNDERGROUND CLEARANCE FOR SWIMMING POOL

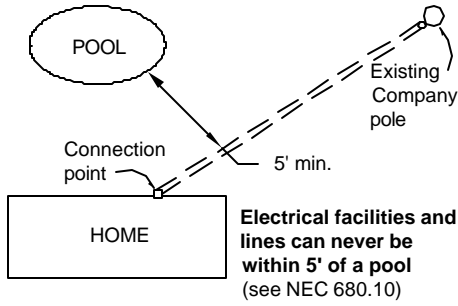

UNDERGROUND REQUIREMENTS FOR PAVED AREAS

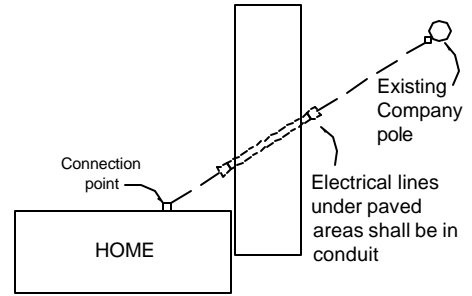

UNDERGROUND FACILITIES CLEARANCES

From shrubs, trees, buildings, fences, decks etc.

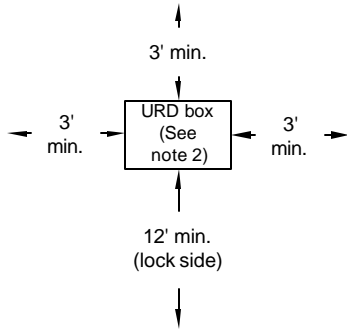

DO NOT BLOCK ACCESS TO ELECTRICAL FACILITIES

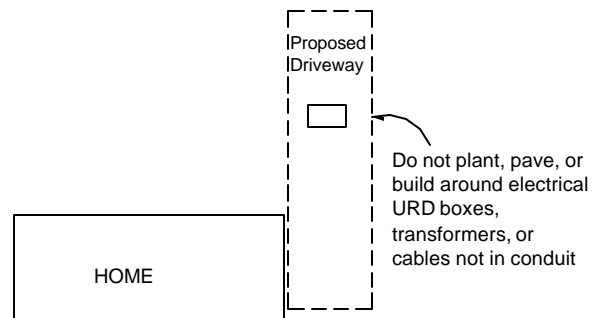

METER CLEARANCES

HOUSE

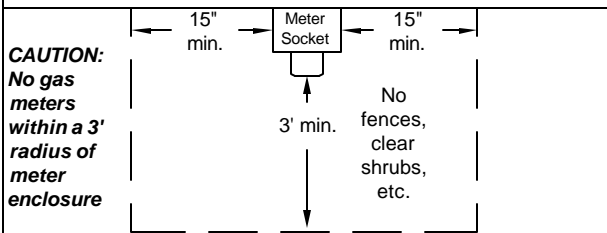

CAUTION:
No gas meters within a 3' radius of meter enclosure

For residential service, the meter is to be located on the outside of the building on the side of the residence within three feet of the front wall and outside of the fences on the side most economical to reach the company's facilities.

Place temporary underground service wire here (underground 30" deep)

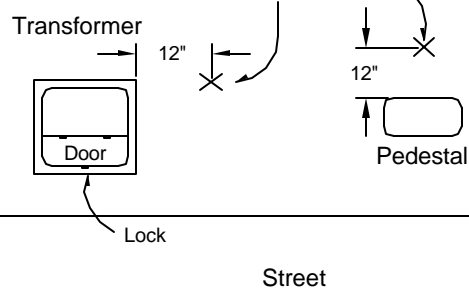

Call 48 Hours Before You Dig 1-888-258-0808

In locations with underground facilities, the Customer shall notify One Call and shall have One Call locate all underground facilities before digging. It shall be the responsibility of the Customer to stay clear of all underground facilities.

Notes:

1. The customer is responsible for clearing and maintaining all right of way.
2. Transformers must meet requirements of drawing SS10.1-1

2	3/08	UPDATED: CUSTOMER INSTALLATION STANDARDS TEAM	DAT	
1	2/05	UPDATED: CUSTOMER INSTALLATION STANDARDS TEAM	DAT	
NO.	DATE:	REVISION	BY:	APPR:

ENTERGY SERVICES, INC.

Underground Service Installation Details & Clearances

APPROVED BY:	JRH	DATE:	April 2002
CHECKED BY:	LKE	SCALE:	None
DRAWN BY:	DAT		



No. SS8.6-6

PLOT 1=1 SH. 1 OF 1

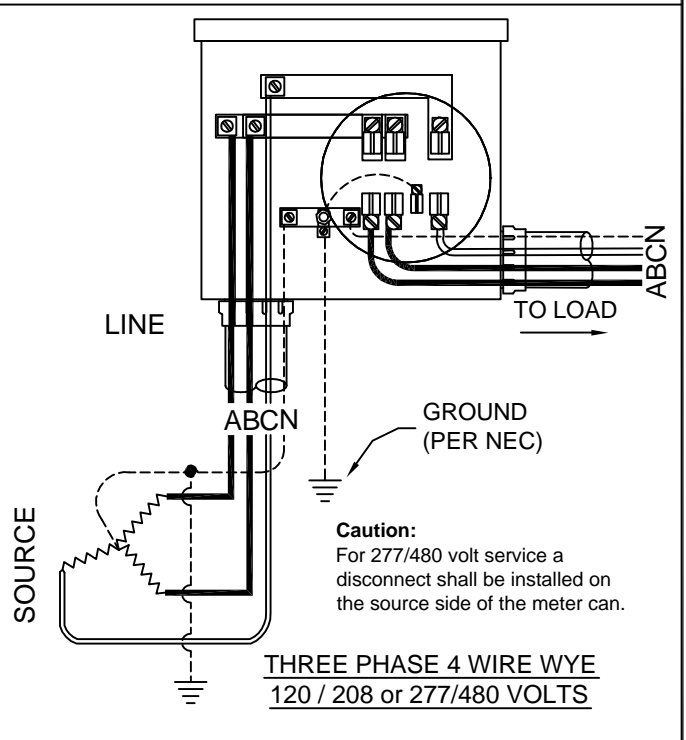
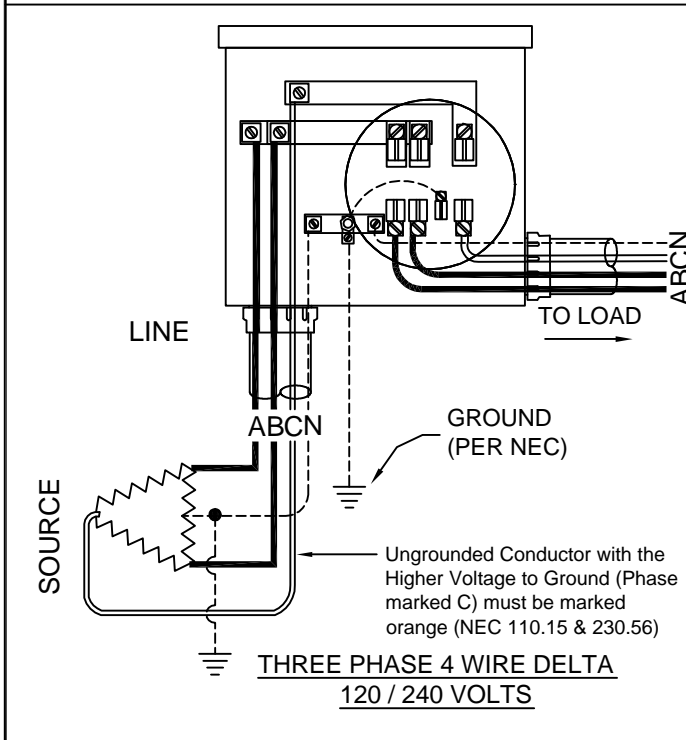
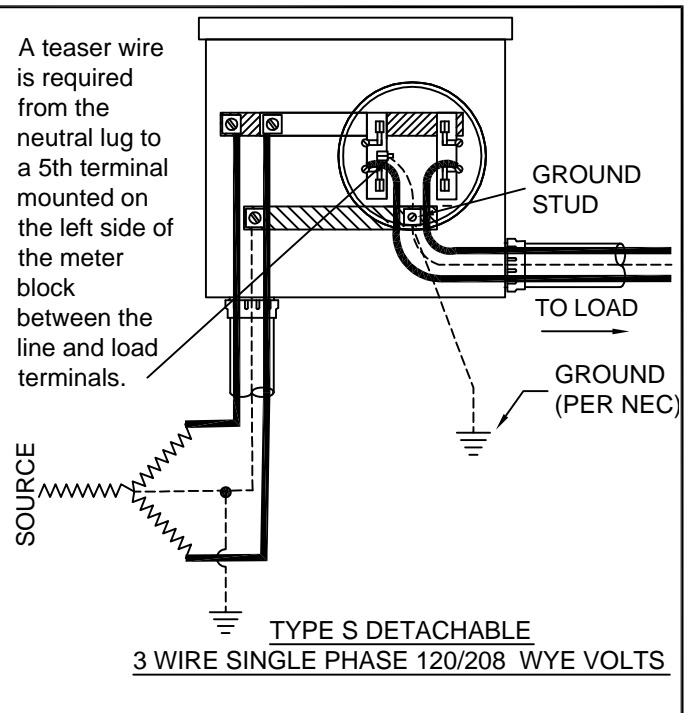
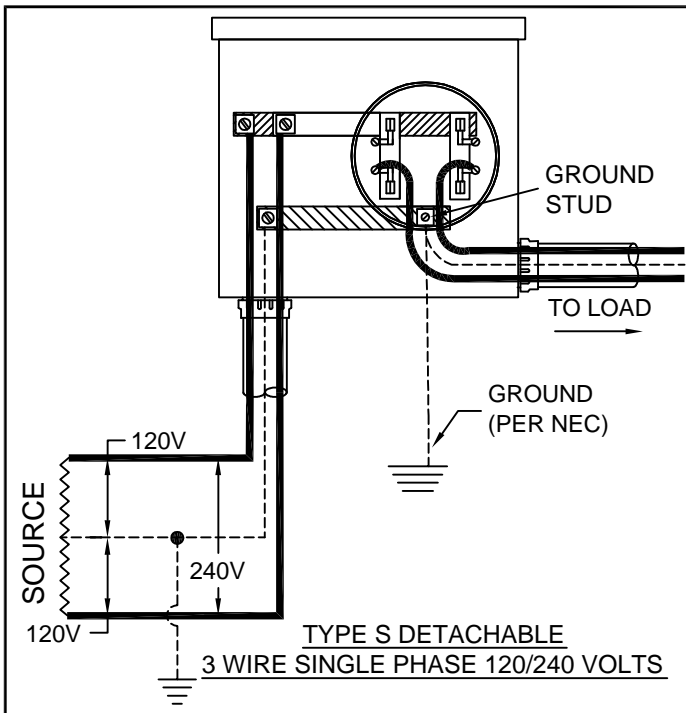

Notes:

1. All diagrams on this drawing show connections when the switch is installed on the right side (see Right Side below) of the meter socket. If the switch is installed on the left side of the meter socket you will need to mirror this diagram (see Left Side below).
2. All sockets, except residential single phase less than 320 Amps, shall have a manual mechanical gang operated bypass switch.
3. Load and supply wires shall not cross in the meter socket (11.1.2.7)

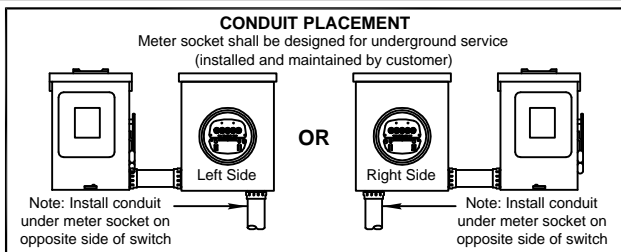

ENTERGY SERVICES, INC.

WIRING DIAGRAM CONNECTIONS FOR UNDERGROUND SELF CONTAINED METERS

APPROVED BY: JRH	DATE: APRIL 2005
CHECKED BY: JED	SCALE: NONE
DRAWN BY: DAT	

No. SS11.8-2

PLOT 1=1 SH. 2 OF 2

Entergy

1	3/08	UPDATED: CUSTOMER INSTALLATION STANDARDS TEAM	DAT
NO.	DATE:	REVISION	BY: APPR: